

CM0805A371R-10

UNCONTROLLED DOCUMENT

PHYSICAL DIMENSIONS:

A	2.00 [.079]	+ 0.20 [.008]
B	1.20 [.047]	+ 0.20 [.008]
C	1.20 [.047]	+ 0.20 [.008]
D	0.15 [.006]	+ 0.10 [.004]
T1	0.55 [.022]	+ 0.10 [.004]
T2	0.46 [.018]	+ 0.10 [.004]

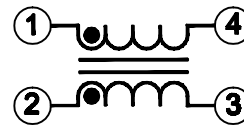
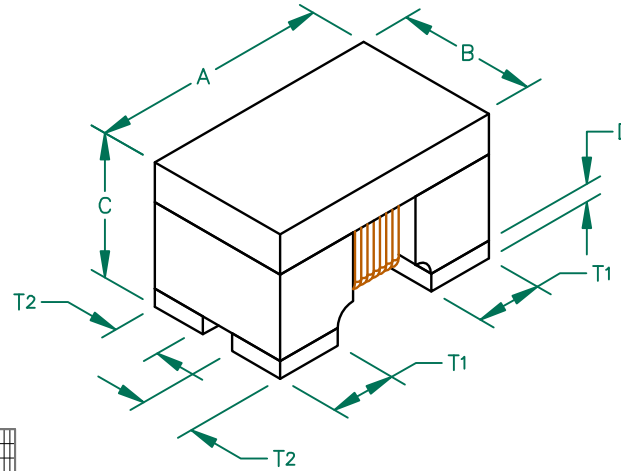

LAND PATTERNS FOR REFLOW SOLDERING

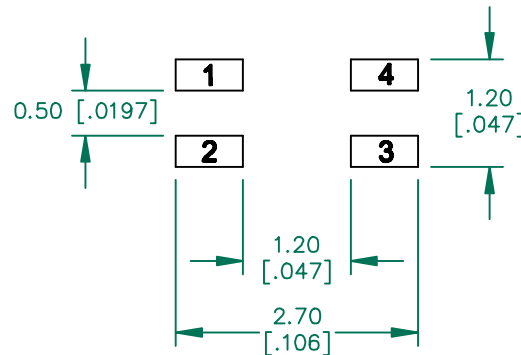

Electrical Characteristics		Nominal	Min	Max
Common Mode Impedance @ 100MHz	(Ω)	370	278	436
DCR	(Ω)	-	-	0.5
Rated Current	(mA)	-	-	100

NOTES: UNLESS OTHERWISE SPECIFIED

1. TAPED AND REELED per CURRENT EIA SPECIFICATIONS 7" REELS, EMBOSSED PLASTIC TAPE 2,000 PCS/REEL.
2. TERMINATION FINISH 100% MATTE TIN.
3. COMPONENTS SHOULD BE ADEQUATELY PREHEATED BEFORE SOLDERING.

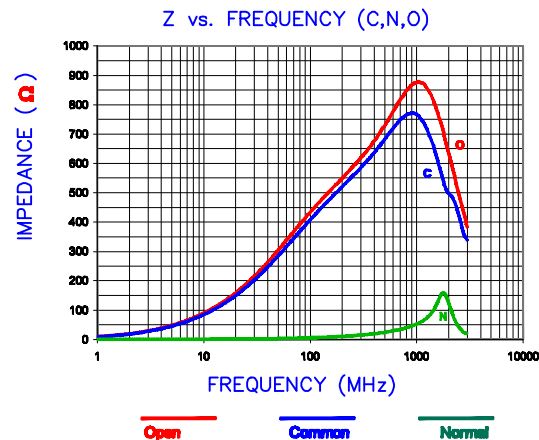
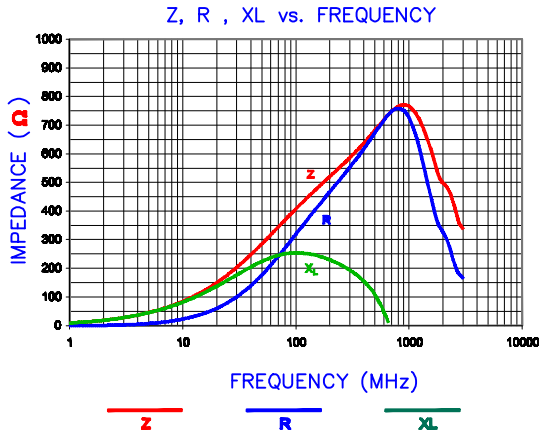

RECOMMENDED SOLDERING CONDITIONS

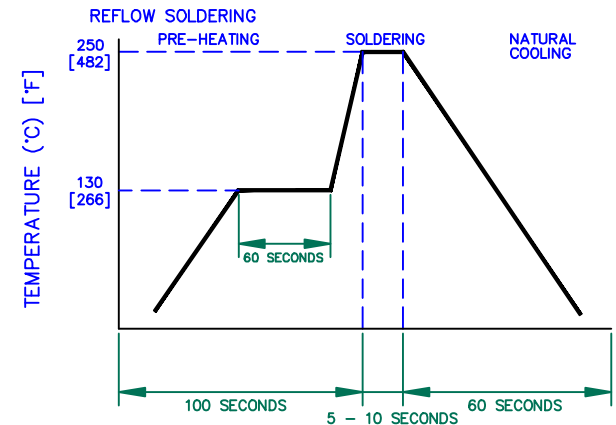

DIMENSIONS ARE IN mm [INCHES].		THIS DOCUMENT CONTAINS INFORMATION WHICH IS PROPRIETARY AND CONFIDENTIAL TO STEWARD. NO PRODUCTION OR PUBLICATION OF THIS DOCUMENT IN WHOLE OR IN PART SHALL BE MADE WITHOUT WRITTEN AUTHORIZATION FROM STEWARD.			
		Steward		<small>part of</small> Laird	
PROJECT/PART NUMBER:		REV	PART TYPE:	DRAWN BY:	
CM0805A371R-10		B	CM CHOKE	JRK	
B	UPDATE COMPANY LOGO	05/10/07	JRK	DATE:	08/11/06
A	ORIGINAL DRAFT	08/11/06	JRK	CAD #	CM0805A371R-10-B
REV	DESCRIPTION	DATE	INT	SCALE:	NTS
				TOOL #	-
				2 of 2	